

Induction Single Stock Pot Range



model: HZT-C15A

- Patented coil mounting rack design (patent no.: ZL 2015 1 0428363.X)
- IPX4 waterproof design to protect against water splash, grease and insect
- 3mm (Tk) frame to protect the glass-ceramic plate from direct weight pressure of stock pot
- Ø450 x 6 mm (Tk) glass-ceramic plate, suitable for Ø500-600 mm stock pot
- Prolong 2-mins cooling fan shut-off time
- 5-level of power control with LED display
- 180° swivel activated faucet

Specifications

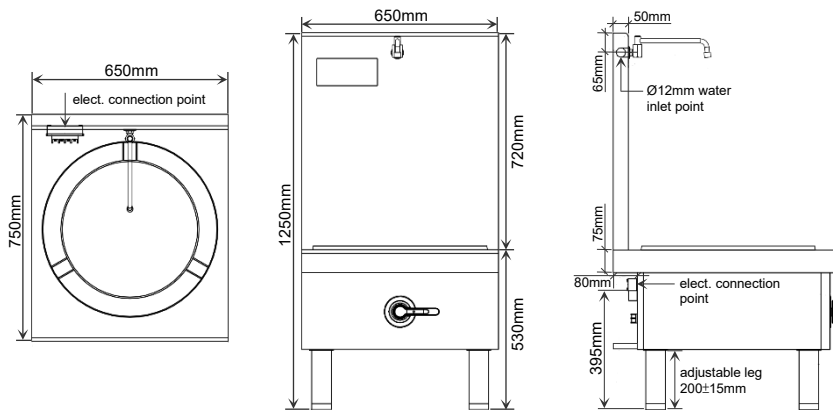

Model:	HZT-C15A
Dimension (WxDxH):	650 x 750 x (530+720) mm
Glass-ceramic plate:	Ø450 x 6 (Tk) mm
Power control:	5-level
Water inlet:	12mm
Electric loading:	380V / 50Hz / 3ph+N, 15kW