

Item: _____

Quantity: _____

Project: _____

Induction Dim-Sum Steamer



model: HZC-C18A9

- Patented coil mounting rack design (patent no.: ZL 2015 1 0428363.X)
- IPX4 waterproof design to protect against water splash, grease and insect
- One piece 1.5mm (Tk) SUS304 stainless steel top
- 5-level of power control with LED display

Specifications

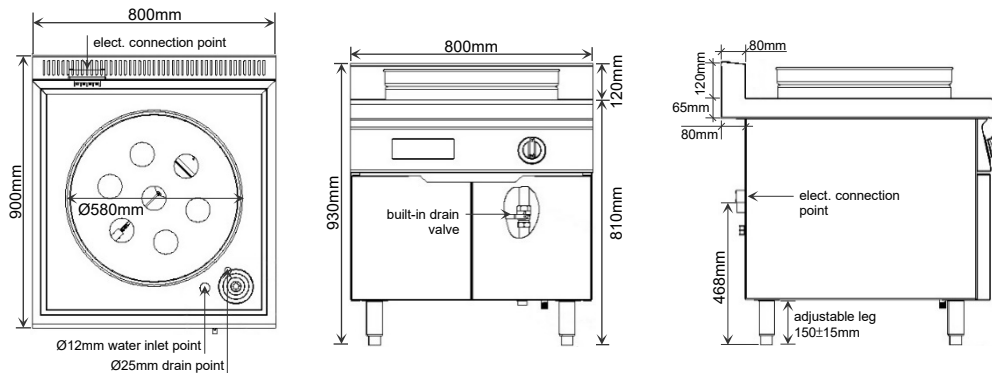

Model:	HZC-C18A9
Dimension (WxDxH):	800 x 900 x (810+120) mm
Power control:	5-level
Water inlet and drain:	12mm inlet / 25mm drain
Electric loading:	380V / 50Hz / 3ph+N, 18kW